

a) Suspension mounting, fixture consisting of several sections of the profile - p. 2

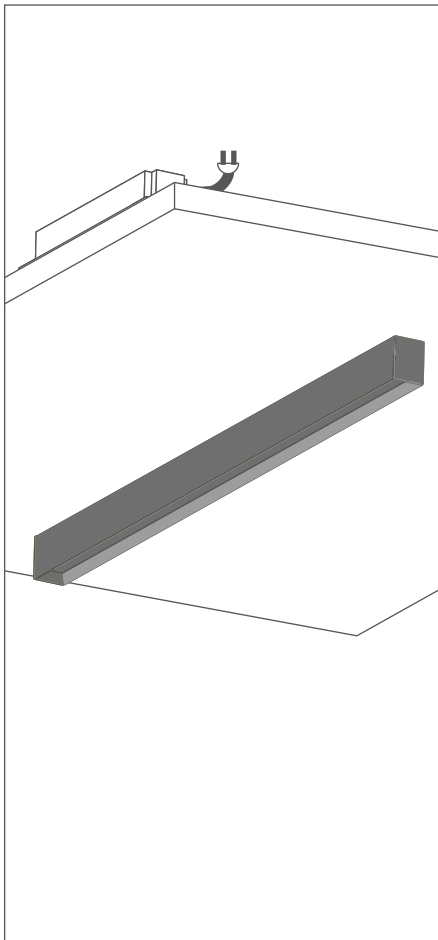

b) Surface mounting, with the use of springs - p. 7

a) Suspension mounting, fixture consisting of several sections of the profile

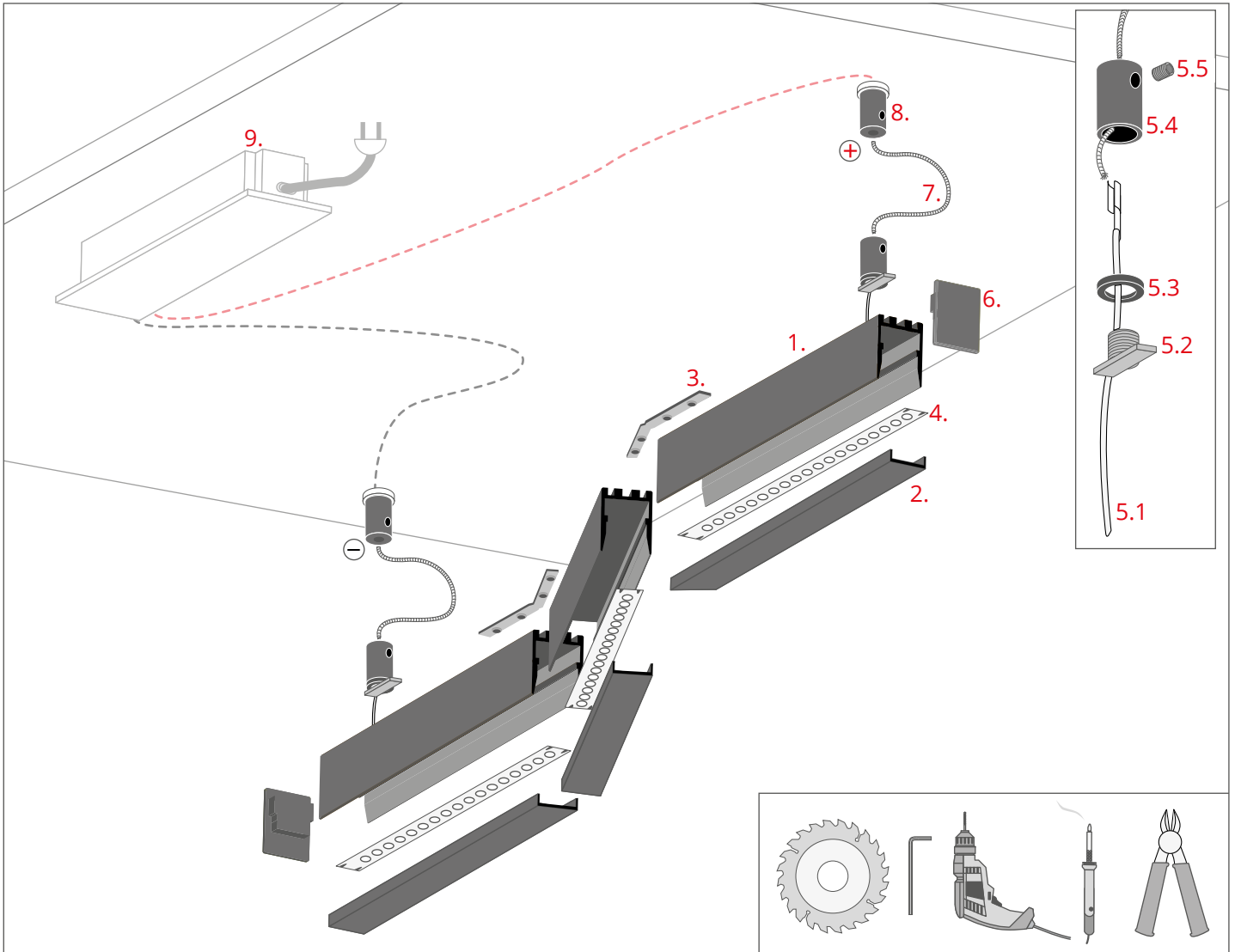

- 1. PDS-ZMG profile (Ref. C1418)
- 2. Cover\*
- 3. Connector\*
- 4. LED strip\*
- 5.1 Fastener (item 5.1)\*
- 5.1 Fastener (item 5.1)\*
- 5.1 Fastener (item 5.1)\*
- 5.1 Fastener (item 5.1)\*
- 5.1 Fastener (item 5.1)\*
- 6. End cap\*
- 7. Steel cable\*
- 8. Ceiling fastener\*
- 9. Power supply (12 V / 24 V)\*

\* The full range of accessories and electronics is available at [www.KlusDesign.com](http://www.KlusDesign.com)

**NOTE!** All LED tapes must be connected to a 12 V or 24 V power supply.

**IMPORTANT:** Not all possible mounting procedures are presented here. More mounting procedures and related accessories can be found at [www.KlusDesign.com](http://www.KlusDesign.com). Drawings of extrusions and accessories in these instructions are simplified and only approximate the actual shapes.

a) Suspension mounting, fixture consisting of several sections of the profile

Ia

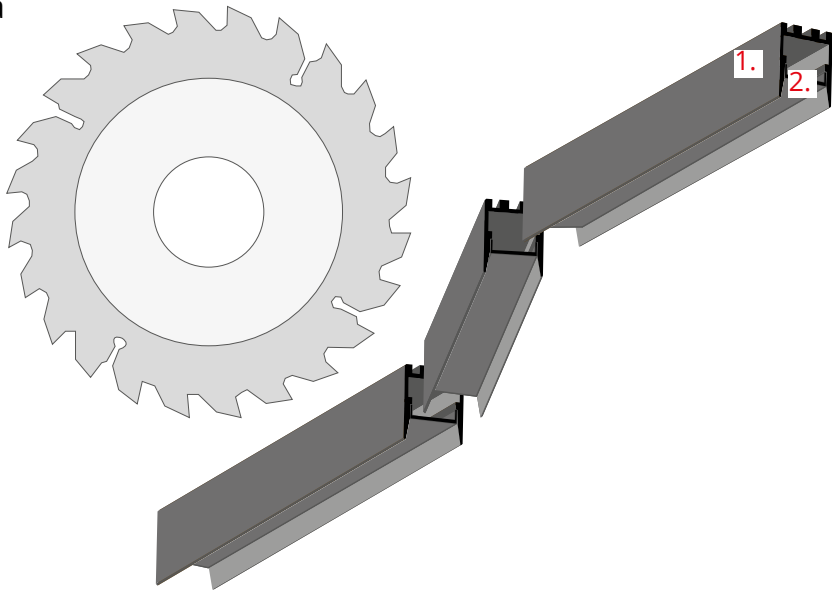

Cut the sections of the PDS-ZMG profile (1) at the selected angle, with the cover (2) installed.

Ila

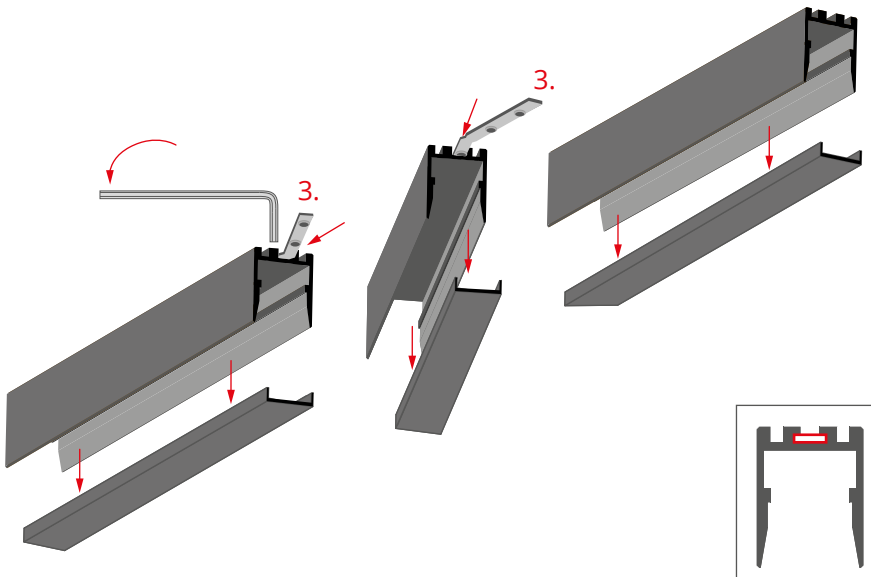

Remove the cut cover sections. Install the connectors (3) in the channels on the back of the profile, locking them with an Allen key.

IIla

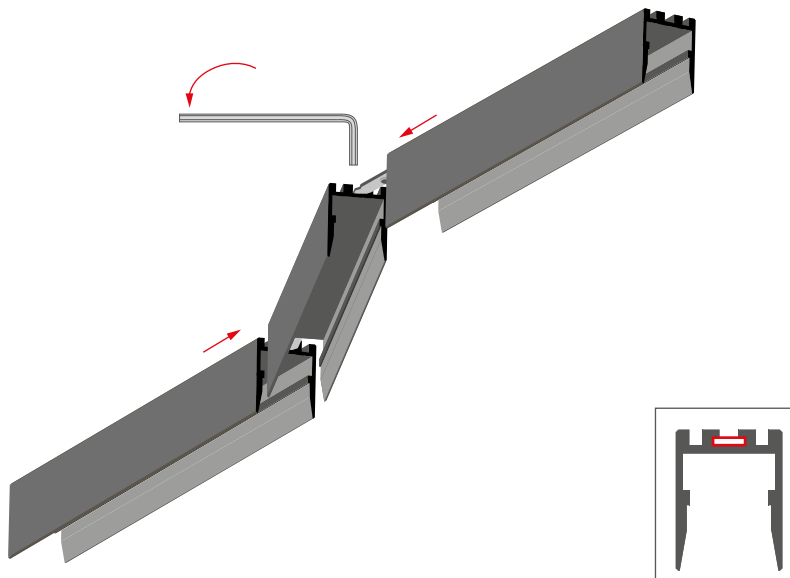

Connect individual sections of the profile with connectors, locking them with an Allen key.

a) Suspension mounting, fixture consisting of several sections of the profile

IVa

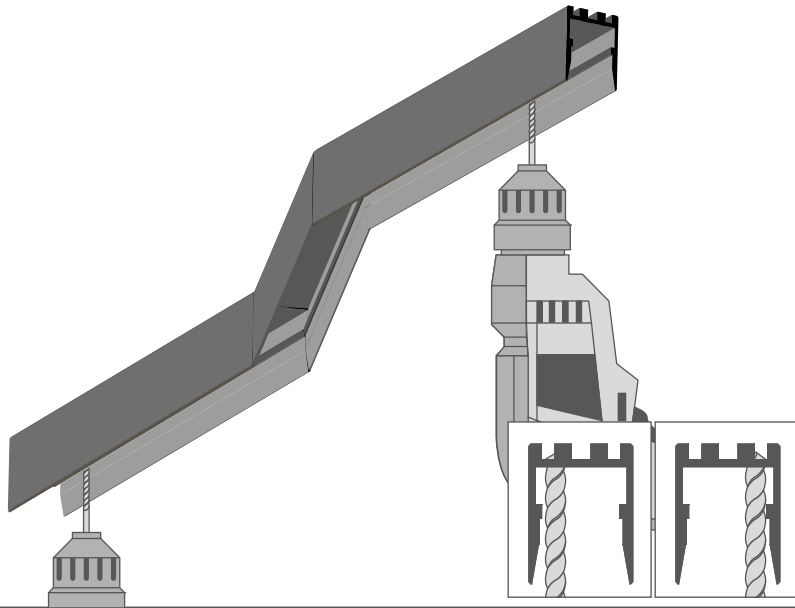

Drill wire holes in the profile. Drill the holes so as not to damage the upper edges of the channel on the profile's back.

Va

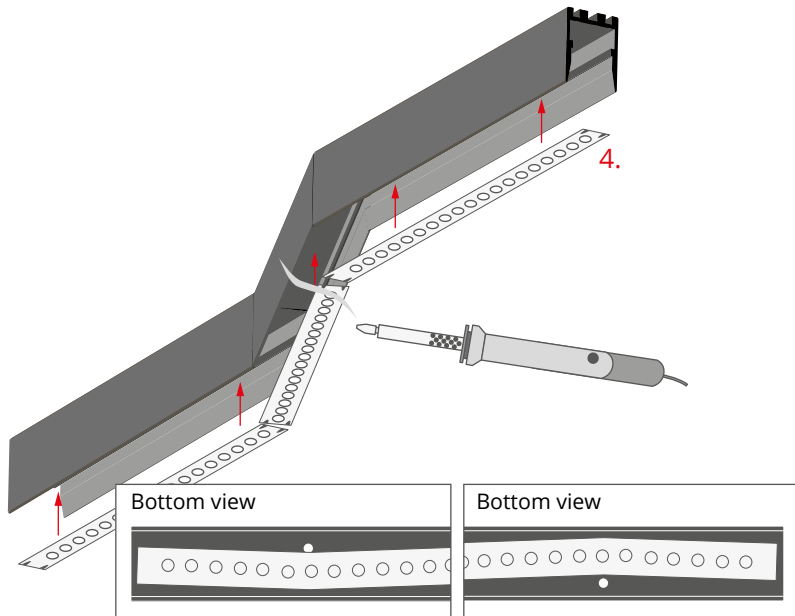

Adhere the LED tape in the profile so as not to cover the holes.

VIa

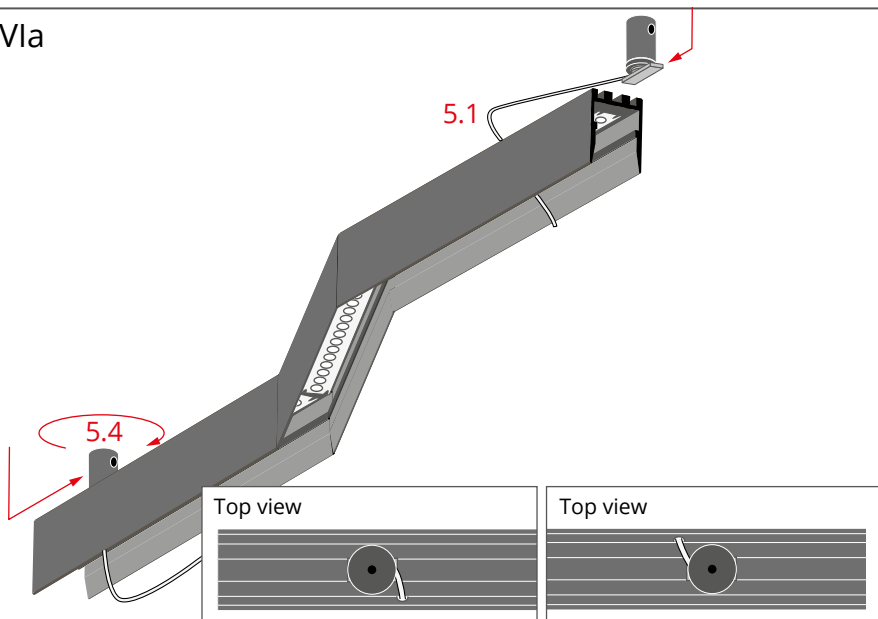

Run the connector wires (item 5.1) through the holes and slide the fasteners into the channel on the back of the profile. Move them as close as possible to the holes and lock them by tightening the heads (item 5.4).

a) Suspension mounting, fixture consisting of several sections of the profile

VIIa

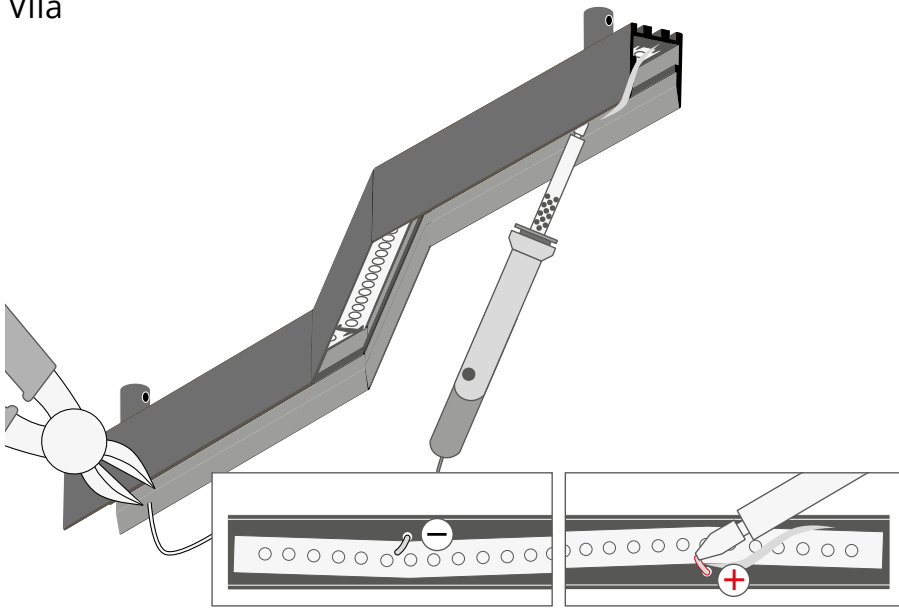

Cut the wires to a length that is convenient for you and solder to the LED tapes.

VIIIa

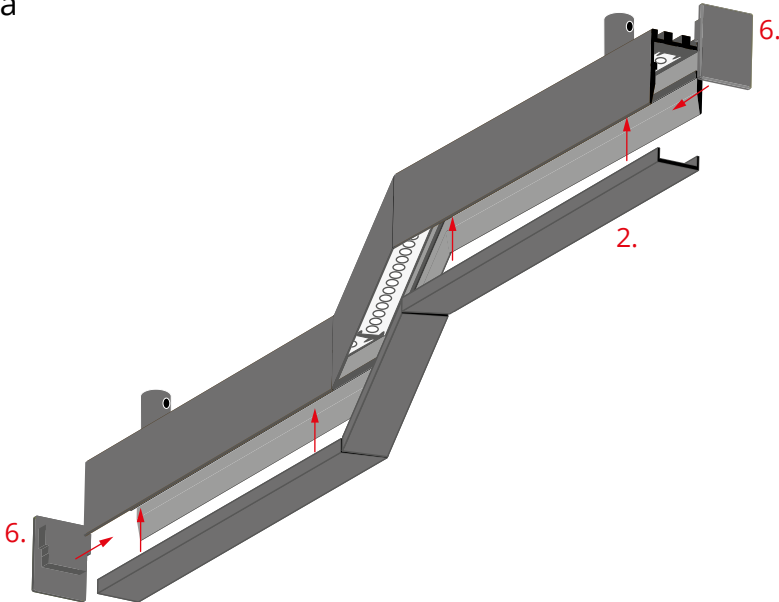

Mount the end caps (6) and the cut cover sections (2).

IXa

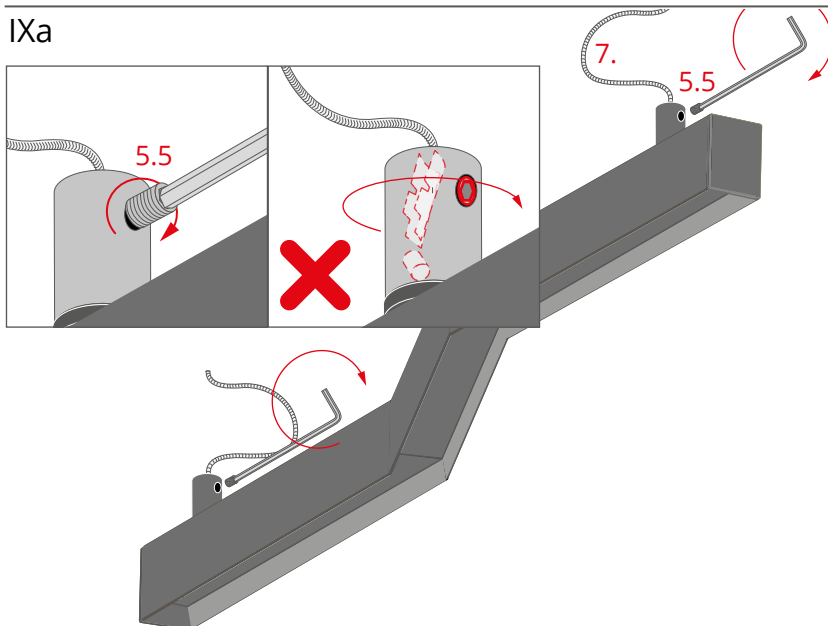

Insert the cables (7) into the holes in the heads of the fasteners. Lock them by tightening the pressure screws (item 5.5) with an Allen key.

**NOTE!** After tightening the pressure screw (item 5.5), **do not turn the head!**

More information about KLUŚ suspension systems available on the website.

a) Suspension mounting, fixture consisting of several sections of the profile

Xa

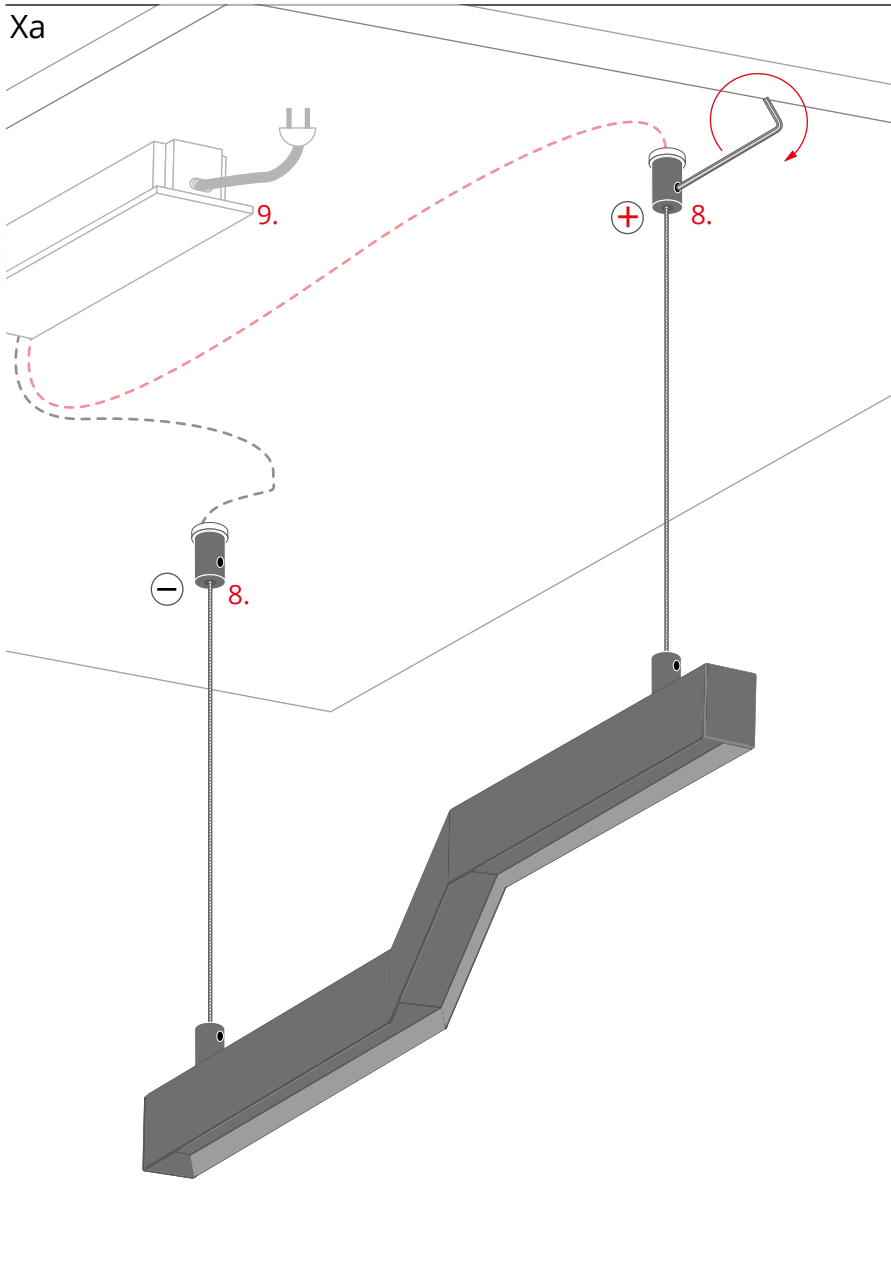

Suspend the lighting fixture from the ceiling fasteners (8), connected to the power supply (12 V / 24 V) (9).

b) Surface mounting, with the use of springs

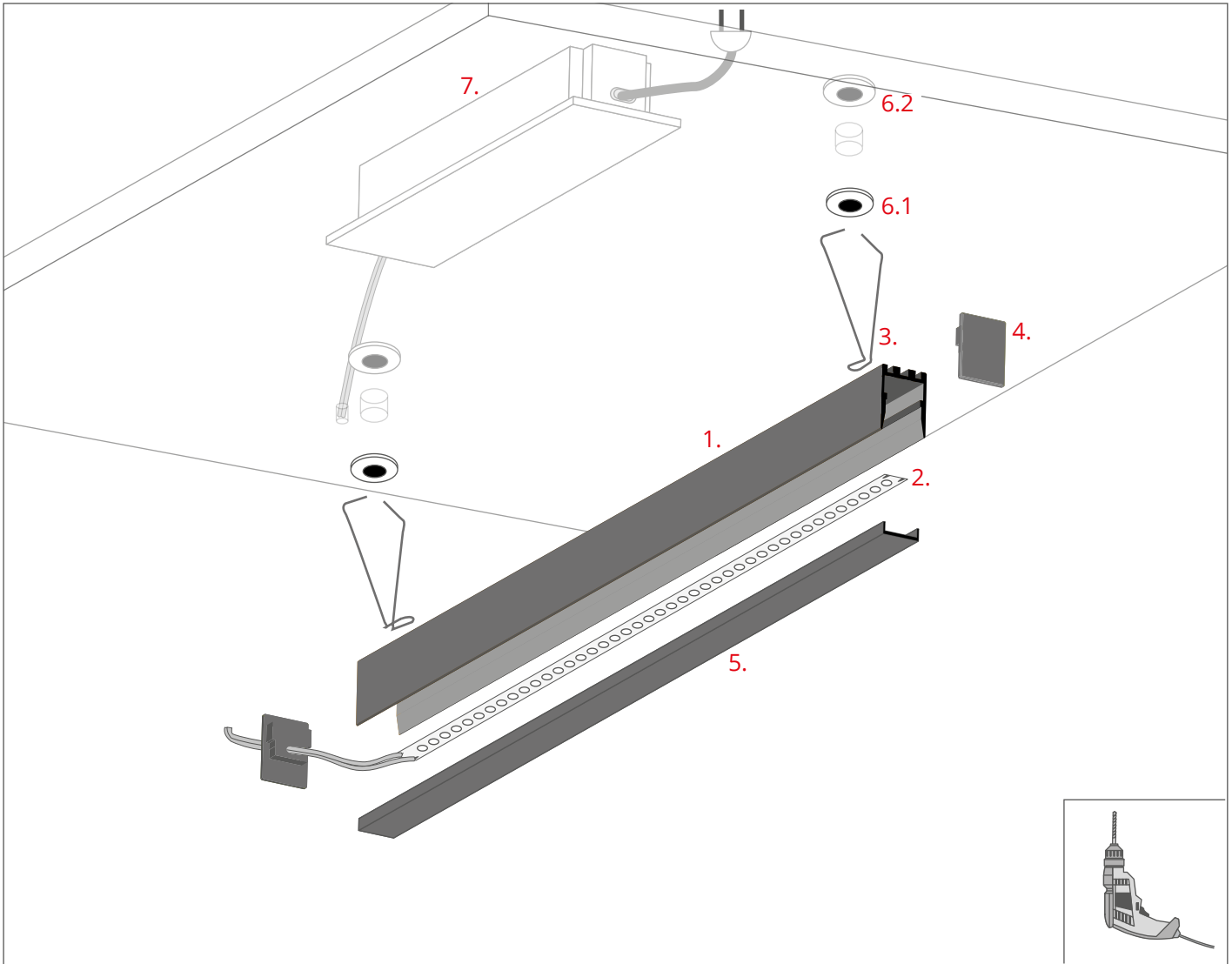

- 1. PDS-ZMG extrusion (Ref. C1418)
- 2. LED strip\*
- 3. Surface mounting spring\*
- 4. End cap\*
- 5. Cover\*
- 6.1 Isolating base (item 7.1)\*
- 6.2 Isolating base (item 7.2)\*
- 6. Power supply (12 V / 24 V)\*

\* The full range of accessories and electronics is available at [www.KlusDesign.com](http://www.KlusDesign.com)

**NOTE!** All LED tapes must be connected to a 12 V or 24 V power supply.

**IMPORTANT:** Not all possible mounting procedures are presented here. More mounting procedures and related accessories can be found at [www.KlusDesign.com](http://www.KlusDesign.com). Drawings of extrusions and accessories in these instructions are simplified and only approximate the actual shapes.

Ib

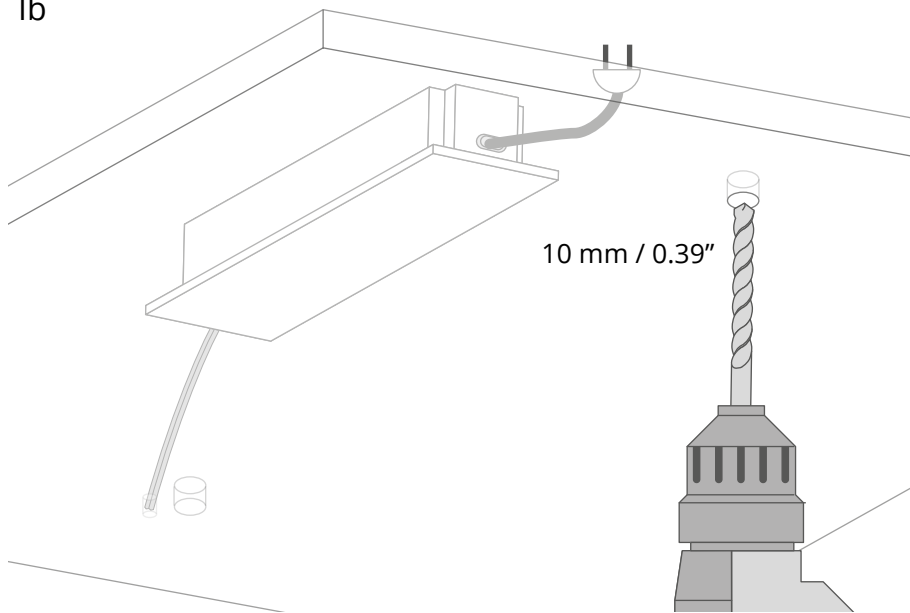

Drill 10 mm / 0.39" holes in the ceiling panel.

IIb

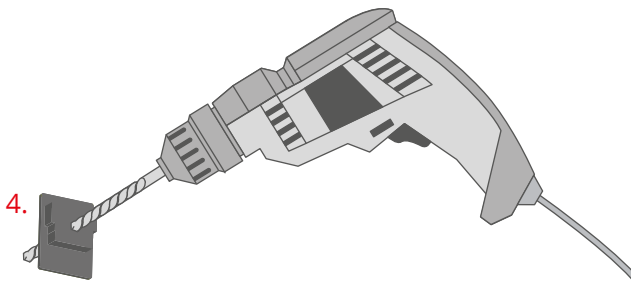

Drill a hole for the cable in one of the end caps (4).

IIIb

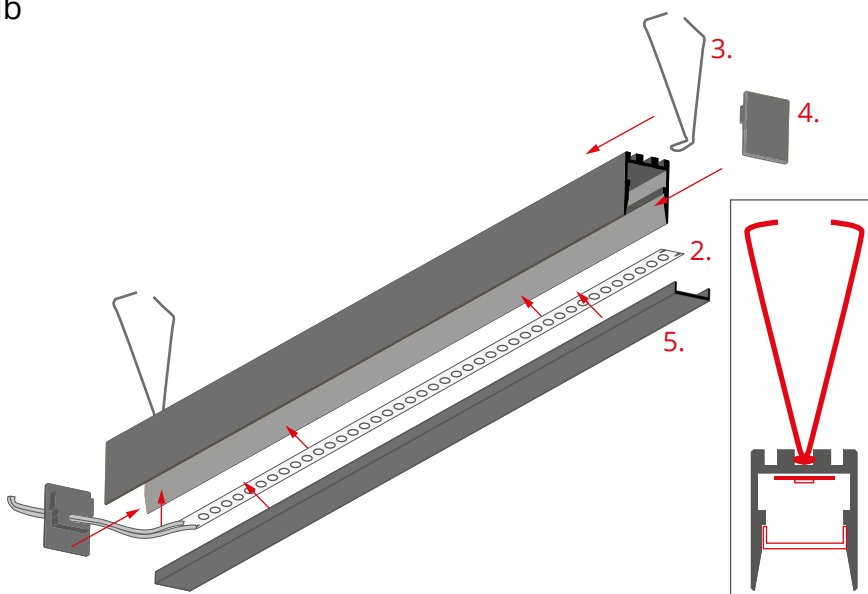

Adhere the LED strip (2) in the profile and lead the cable through the hole in the end cap.

Insert the surface mounting springs (3) into the channels (small locks) on the back of the extrusion.

Mount the end caps (4) and the cover (5).

IVb

Slide the isolating bases (6.1) onto the surface mounting springs and press them against the back of the extrusion.

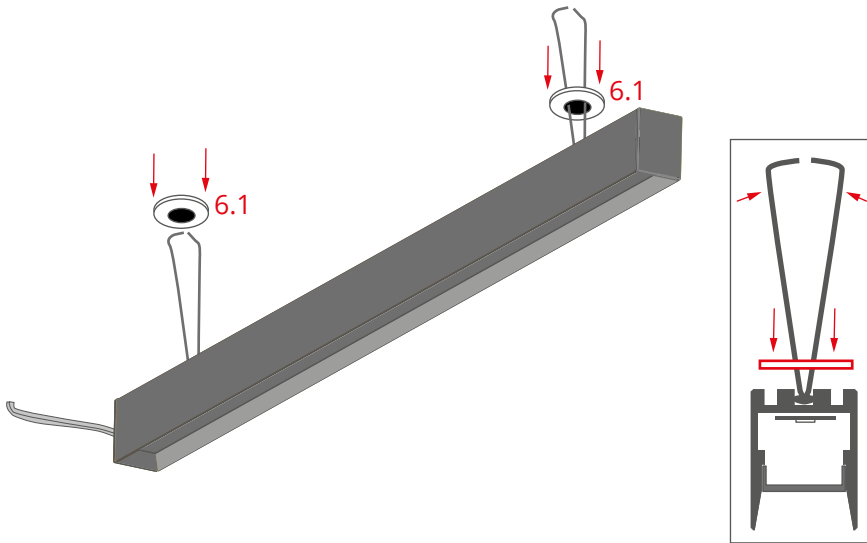

Vb

Connect the power cable to the power supply 12 V / 24 V (7).

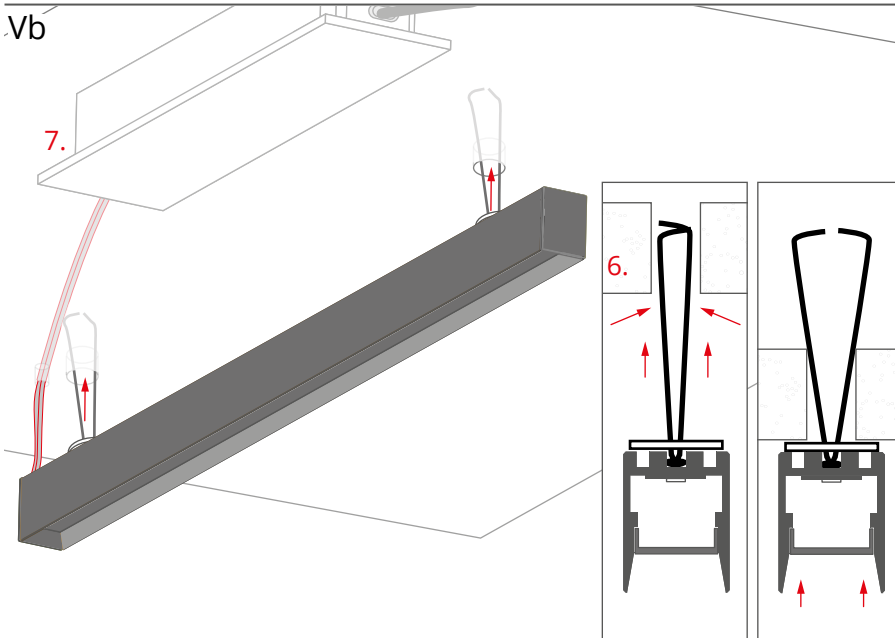

VIb Top view

Slide the isolating bases (6.2) onto the spring arms protruding from the holes on the inside of the ceiling panel.

