

- 1.1 MOD-100 profile (item 1.1)
  - 1.2 MOD-100 profile (item 1.2)
  - 1.3 Locking bolt
  - 2. LED Tape\*
  - 3. Gland\*
  - 4. Power supply (12 V / 24 V)\*
  - 5. Cover\*
  - 6. Fastener\*
  - 7. Metal gland\*
  - 8. End cap\*
  - 9. Bolt
- } 18049

- 10. Ceiling fastener\*
- 11. Steel wire\*
- 12. Reflector\*
- 13. Cover\*

\*The full range of accessories and electronics is available at [www.KlusDesign.com](http://www.KlusDesign.com)

**NOTE!** All LED tapes must be connected to a 12 V or 24 V power supply.

**IMPORTANT:** Not all possible mounting procedures are presented here. More mounting procedures and related accessories can be found at [www.KlusDesign.com](http://www.KlusDesign.com). Drawings of extrusions and accessories in these instructions are simplified and only approximate the actual shapes.

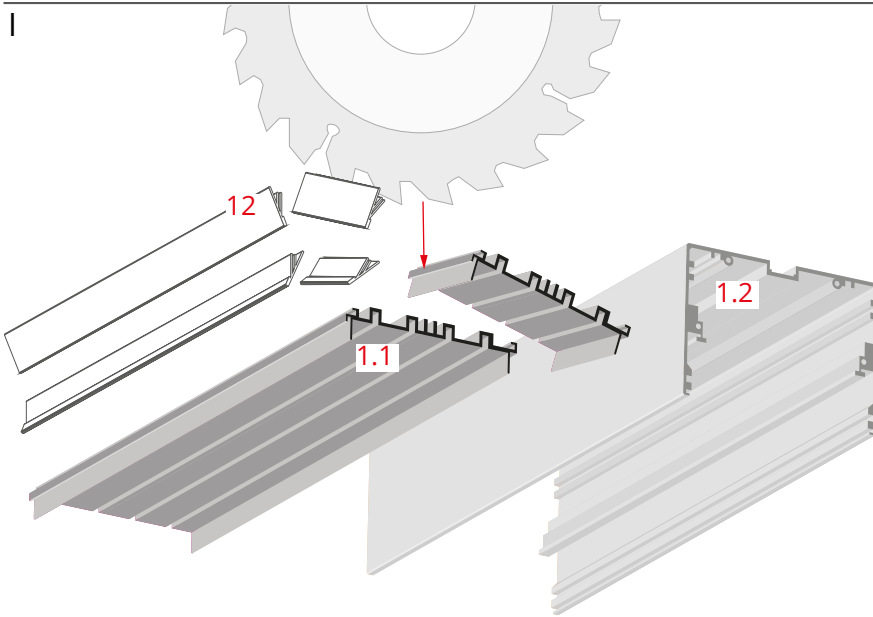

Shorten the extrusion item (1.1) by 12 mm / 0.47" relative to item (1.2).

Shorten the reflectors (1.2) by 12mm / 0.47" (to make them as long as the extrusion item 1.1)

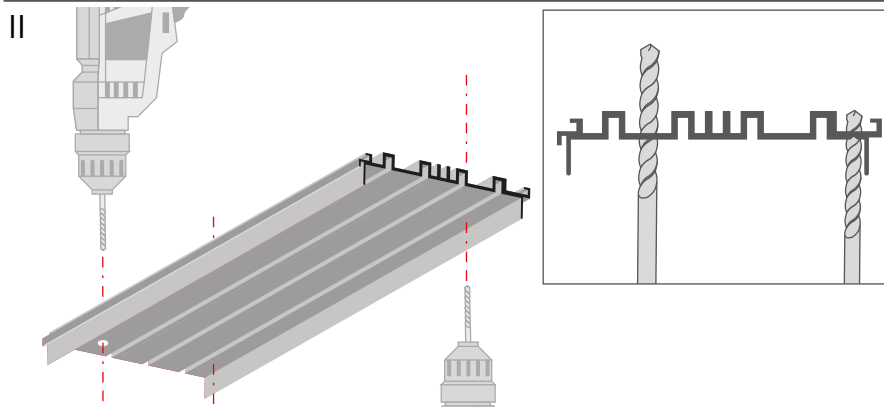

a. Drill holes for locking bolts in the profiled auxiliary line. The required number of holes is:

2 / 1m of the profile  
4 / 2m of the profile  
6 / 3m of the profile

b. Drill a hole for the gland.

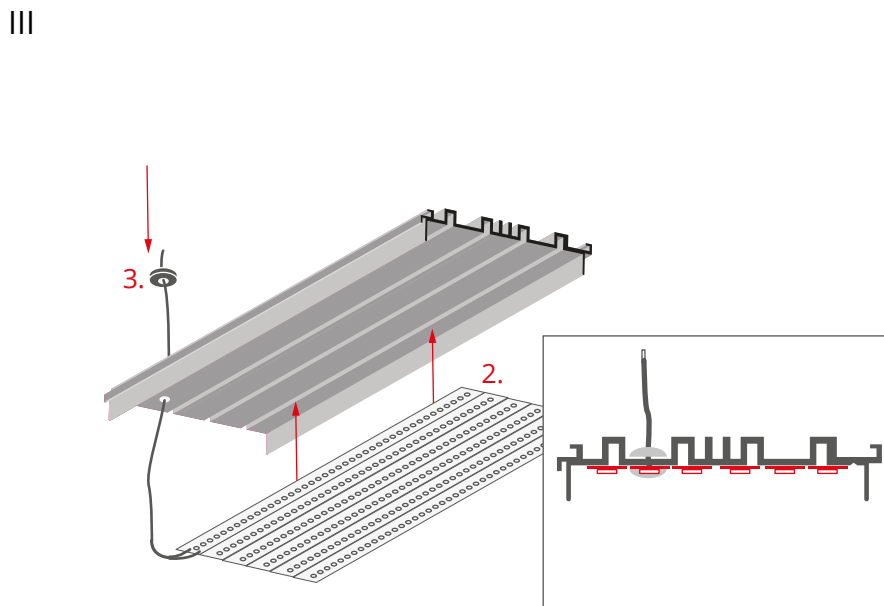
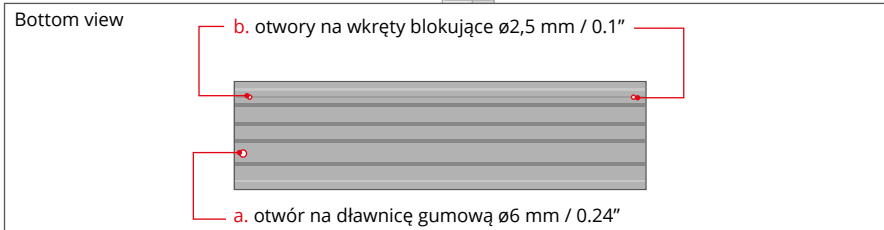

Install the LED tapes (2), insert the gland (3) and feed the power cable through it.

IV

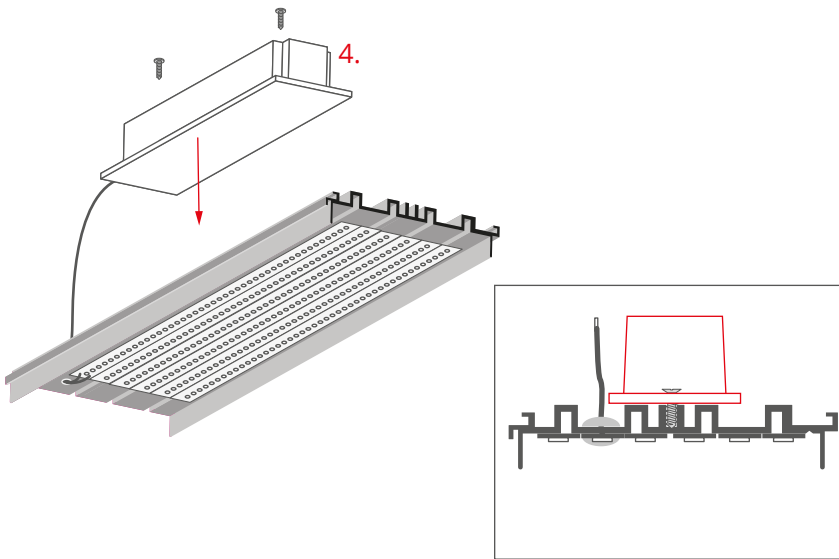

Mount the power supply (4) on the back of the extrusion.

V

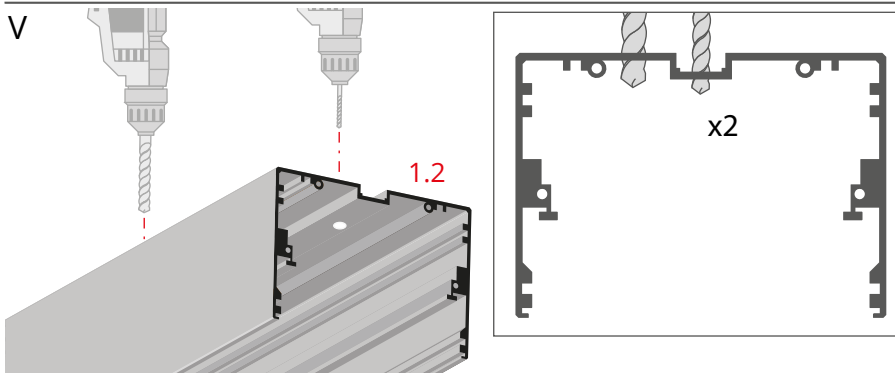

a. Drill two holes for the fasteners in the channel on the back of the extrusion (1.2). They do not have to be in a specific location.

b. In the channel on the back of the extrusion drill a hole for the gland. minimal distance between the hole and the edge of the extrusion is 8 mm / 0.31".

c. Drill a hole for the gland near the channel, where you will run the power cable from the ceiling.

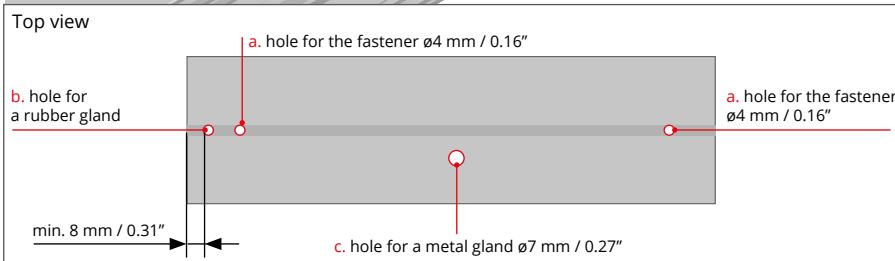

VI

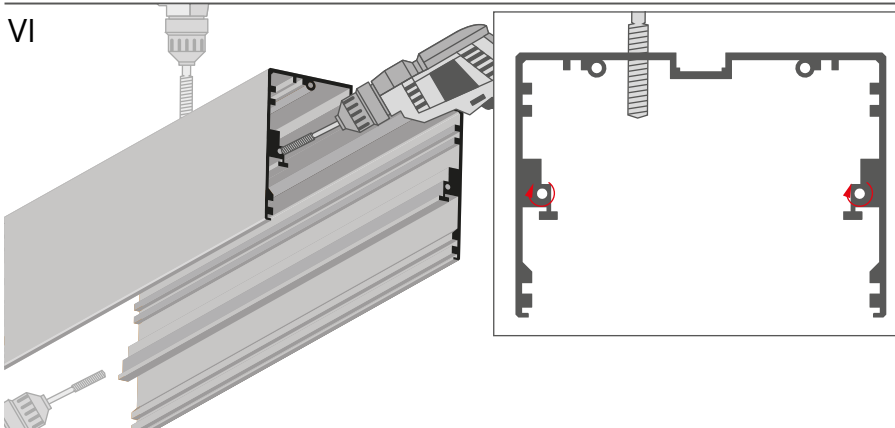

a. On both sides, from the side of the profile cross-section, thread the sockets for end cap bolts to a depth of approx. 15 mm / 0.59". (M3 tap)

b. Thread the hole for the metal gland (M8x1 tap).

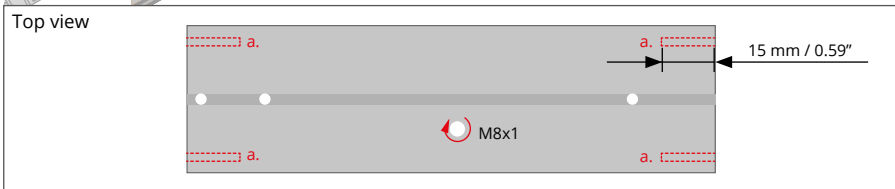

VII

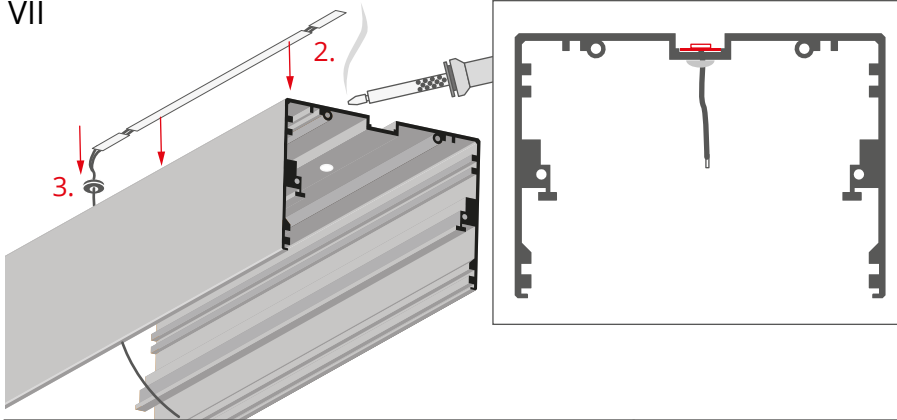

Install the LED tape (2).

Then connect the poles of the tape using a soldering iron and short wires.

Mount the gland (3) and feed the power cable through it.

Top view

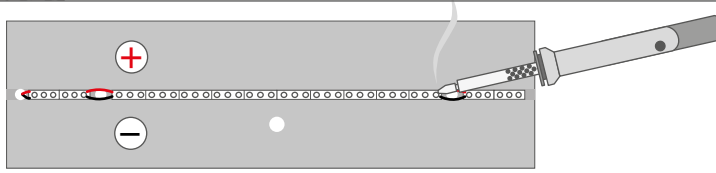

VIII

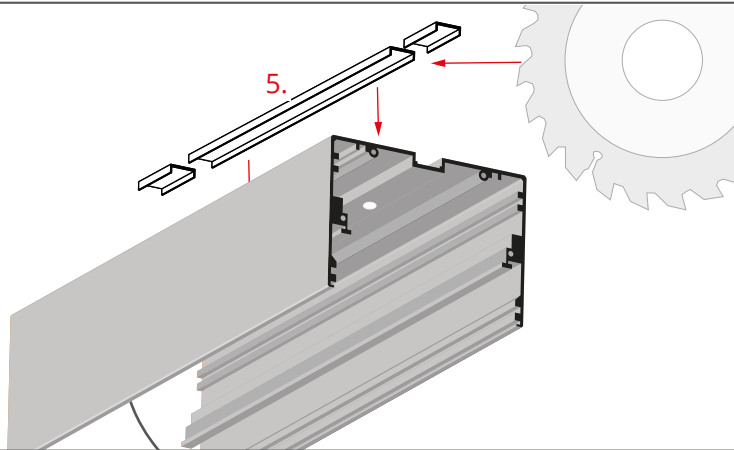

Attach the cover (5) between the holes for the fasteners leaving 5 mm space between the cover sections.

Top view



IX

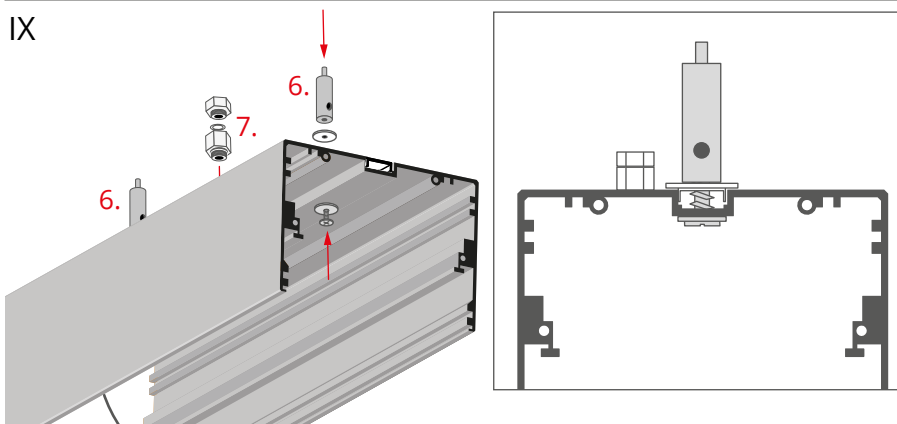

Attach the fasteners (6) and mount the metal gland (7).

Top view

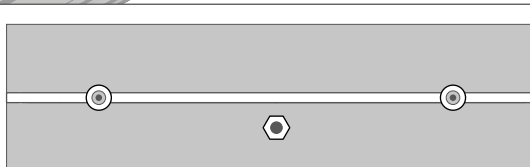

X

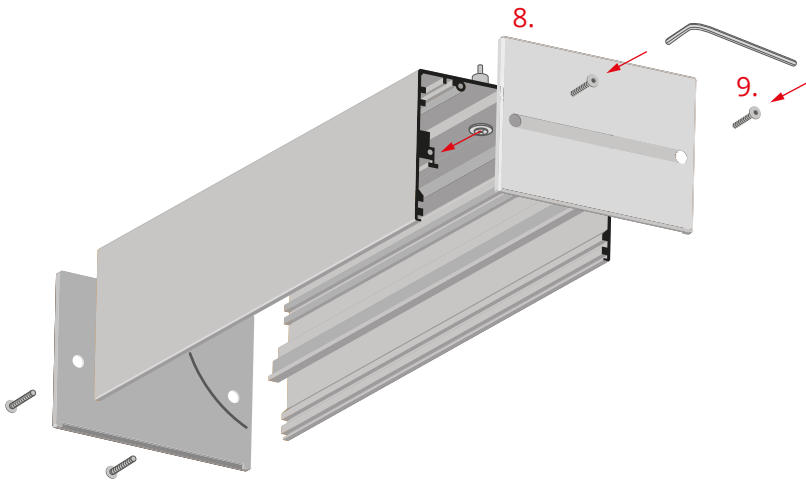

Mount end caps (8) and secure them with bolts (9).

NOTE! The end caps can also be mounted at stage XIV.

XI

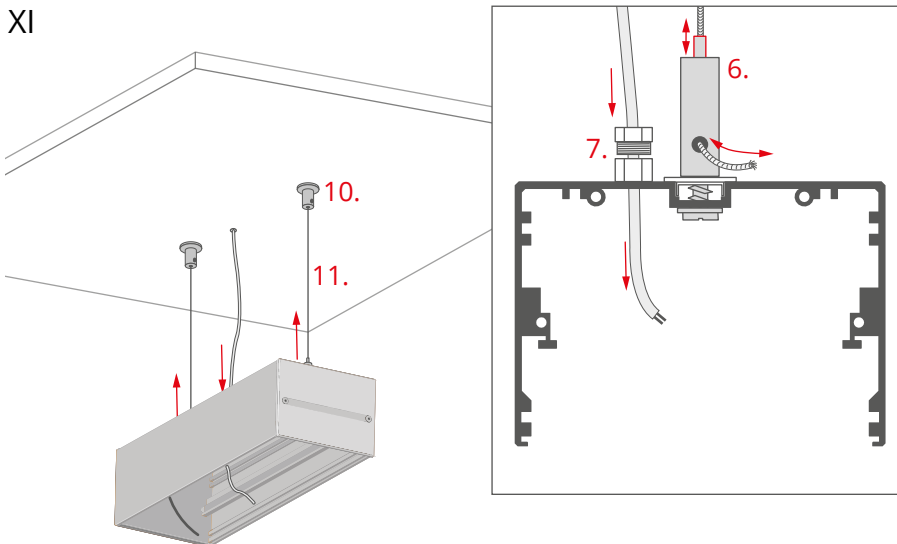

Fasten the extrusion on steel wires (11) to the ceiling fasteners (10). The suspension length can be adjusted by pressing the upper part in the fastener body (6).

Feed the main power cable through the metal gland (7) and tighten the top nut.

XII

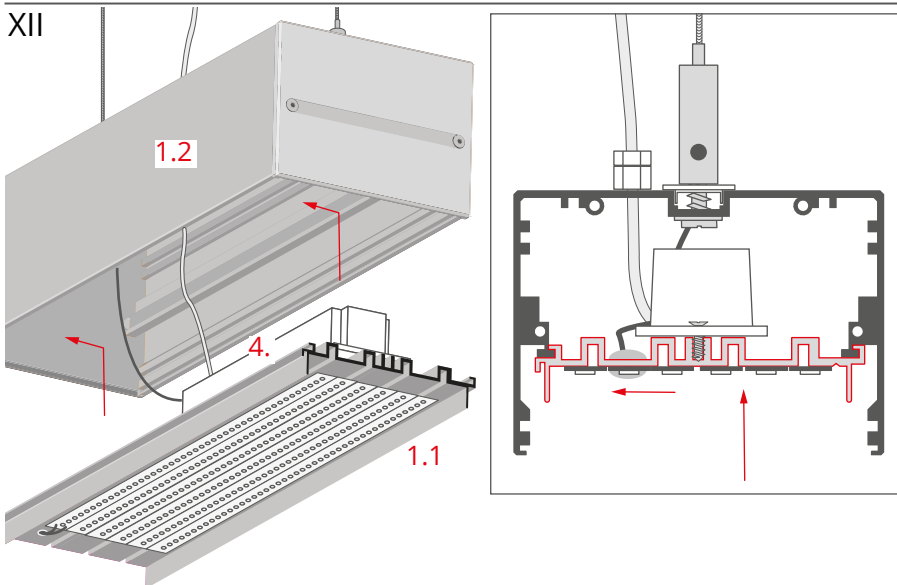

Connect the power supply (4) to the power cable.

Connect both extrusion items (1.1, 1.2) by inserting and moving item (1.1) as shown in the figure.

XIII

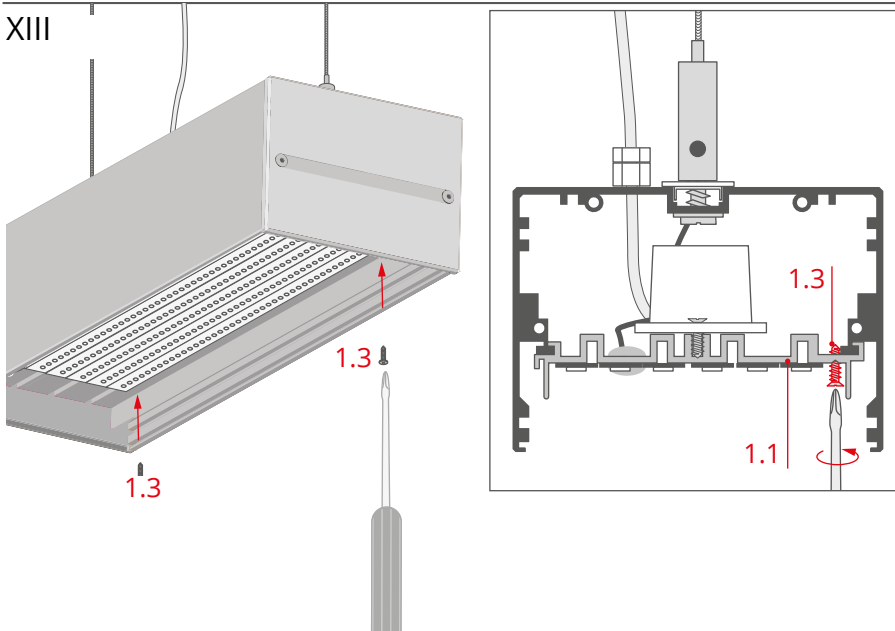

Secure the extrusion item (1.1) against slipping out by screwing the locking bolts (1.3) into the pre-drilled holes.

XIV

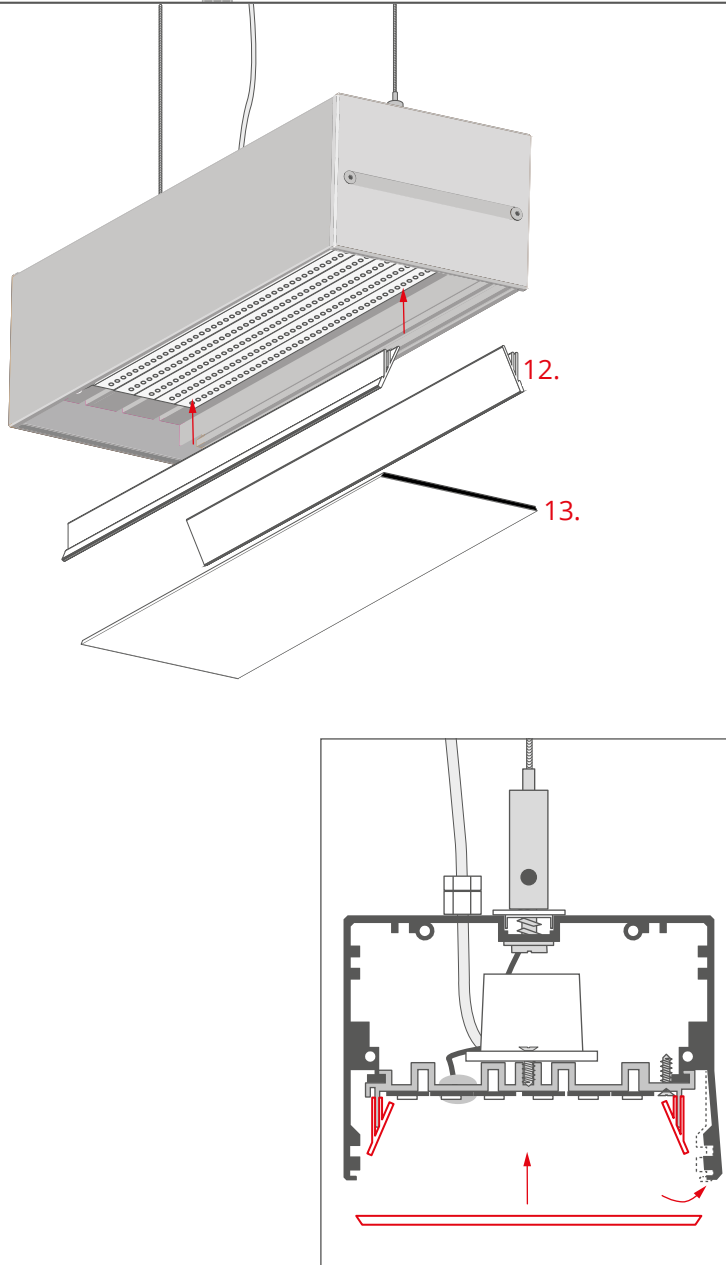

Mount the reflectors (12).

Mount the bottom cover by slightly bending one wall of the extrusion (13).

The cover needs to be the same length as the extrusion.